



# Data Sheet

## RISH PQA

Power Quality Analyzer



Measure



Control



Record



Analyze

RiSH PQA is a compact state of art power quality analyzer designed for utilities, as well as for industrial & commercial customers.

The meter is equipped with 5" TFT Colour display for easy graphical representation of Harmonics, Phasors and Waveforms.

RiSH PQA can continuously monitor power quality in accordance with EN50160, also the built in flexibility allows the user to set customized setting to do power quality analysis.



The meter is capable of measuring harmonics as per IEC 61000-4-7, inter-harmonics, dips, swells, interruptions.

Intelligent algorithm allows user to monitor multiple parameters at a glance on a single screen, which helps in analyzing power quality issues very easily.

The Power Quality Analyzer also monitors demand and measures energy with accuracy of class 0.2S as per IEC62053-22.

The meter supports memory card (microSD, up to 8GB) for recording of events and power quality parameters as per EN50160. Communication can be done via modbus over RS485.

RiSH PQA is supported with Power Configurator application software for configuring and displaying data via RS 485. USB should be used to download data on PC and for firmware upgrade process.

### Areas of Applications:

- Monitoring of all power quality parameters for early warnings & corrective actions
- Power quality report generation as per EN 50160
- Fault analysis in case of power failure
- Disturbance analysis
- Supervision and preventive maintenance of an installation
- Load trend analysis

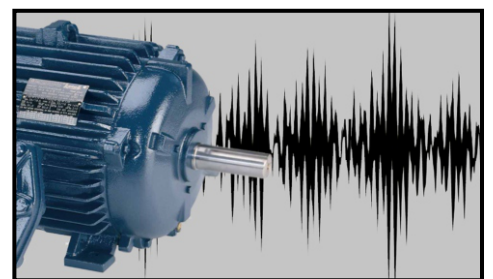

Measure



Control



Record



Analyze

## Understanding EN50160:

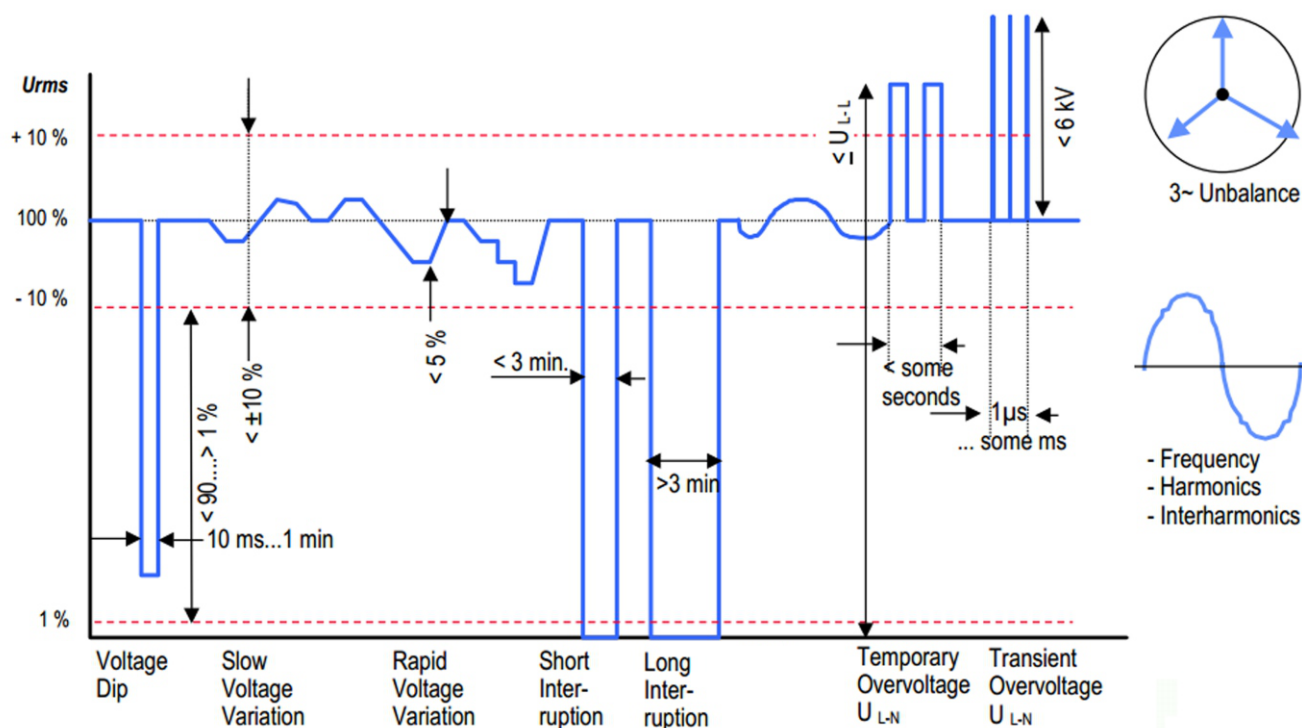

### RiSH PQA *measurement as per EN50160:*

- Voltage Swell & Dip Detection.
- Voltage Variation Detection.
- Detection of Voltage Interruptions.
- Unbalance Detection & Measurements.
- Frequency Variation Measurement.
- Per Phase Individual Harmonic Measurement as per IEC 61000-4-7 up to 63rd harmonic, Group and Sub-Group Harmonics Measurement
- Individual, Group and Sub-Group Inter-Harmonics Detection & Measurement.
- Thresholds as per EN50160 or user selectable thresholds.
- %THD of per Phase Voltage & Current.
- Measurement of RMS Value of Harmonics.
- Time Stamping for Power Quality Disturbances.



Measure



Control



Record



Analyze

### Product Features:

- Measures all basic electrical parameters like Voltage, Current, Power, Demand and Energy.
- Energy Class 0.2S as per IEC 62053-22
- Measurement in all Four Quadrants
- 5" TFT Display with 480x272 pixels resolution



#### Meter:

- **Basic**
  - TRMS Voltage & Current Measurement over 10 cycles for 50Hz and 12 cycles for 60Hz
  - Crest Factor and Earth to Neutral Voltage (EN) Measurement
- **Distortion**
  - % THD & % TID Measurement of per Phase Voltage & Current
  - Shows Voltage and Current amplitudes of 4 user-settable frequencies
  - Signed & Unsigned Power Measurement
- **Unbalance**
  - Shows %Unbalance of Voltage and Current
  - Shows %Imbalance of Voltage and Current
- **System**
  - All system related parameters are displayed
  - Shows Minimum and Maximum System Voltage and System current
- **Power/Energy**
  - Active, Reactive & Apparent Power and Energy Measurement
  - Independent Import & Export Energy Counter
- **Demand**
  - Active, Reactive, Apparent demand, Current demand measurement
  - User selectable demand interval



Basic		
	Vrms (V)	Vpeak (V)
L1	230.01	325.29
L2	229.96	325.23
L3	230.00	325.54
EN	0	0

Volt. L-N  
 Volt. L-L  
 Current  
 Crest Factor  
 Angle / PF

<< Previous   Parameter   Next >>   Favourite   Exit

System	
Voltage (V)	229.99
Current (A)	0.9999
Frequency (Hz)	50.000
Voltage THD (%)	0
Current THD (%)	0
Phase Sequence	Normal

Basic  
 System Power  
 Min. / Max.  
 Arithmetic  
 Vector

<< Previous   Parameter   Next >>   Favourite   Exit

Demand	
RMS Current Demand L1	0.4000
RMS Current Demand L2	0.4000
RMS Current Demand L3	0.3999
RMS Current Demand Avg.	0.4000
System Current Demand	1.1999

Current Dmd.  
 System Dmd.  
 Max Demand  
 Coincid. Dmd.  
 Coincid. PF

<< Previous   Parameter   Next >>   Favourite   Exit



Measure

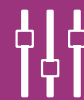

Control



Record



Analyze

- **Favourite**
  - Display of parameters readings in large fonts.
  - User assignable screens.
  - 20 different user settable parameters.

<b>Sys Voltage</b>	<b>229.99</b> V
<b>I RMS LN</b>	<b>0.0011</b> A
<b>Max Sys Curr</b>	<b>1.9993</b> A
<b>VAh Tot</b>	<b>0.175</b> kVAh
1	Prev Next Exit

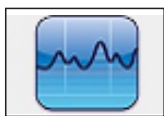

### Scope:

- Real Time Representations of Three Phase Voltage and Current Waveform.
- Cursor for easy analysis.
- User configurable colors for each channel.

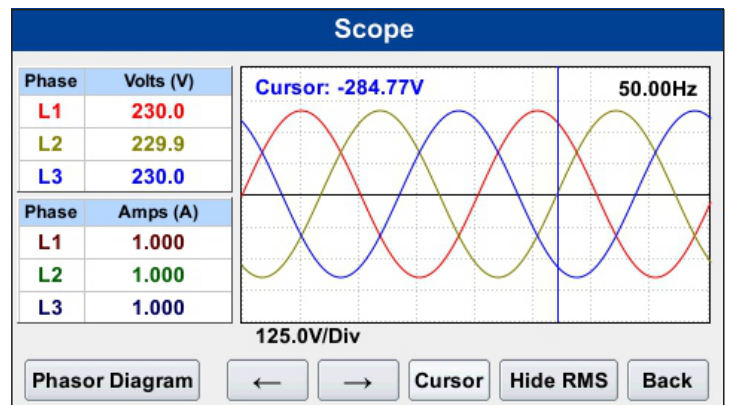

### Phasor Diagram

- Complete Three Phase System overview at a glance for System analysis (Phasor Diagram).
- Display of per Phase Vrms & Irms.
- Phase Angle of all Phases.
- User configurable colors for each channel.

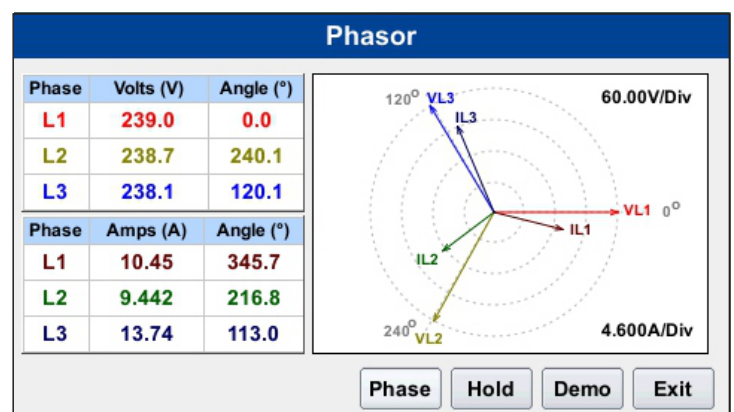

Measure



Control



Record



Analyze



### Harmonics:

- Harmonics measurement as per IEC 61000-4-7 Class II
- Per Phase Voltage, Current & Power Bar Graph Representation of up to 63rd Harmonic.
- List of Harmonic Components with magnitude & scaled to percentage of fundamental component.
- Inter-Harmonic Component representation.
- Odd, Even, Total THD as well as TID.
- Zoom function for easy analysis of each Harmonic Component.

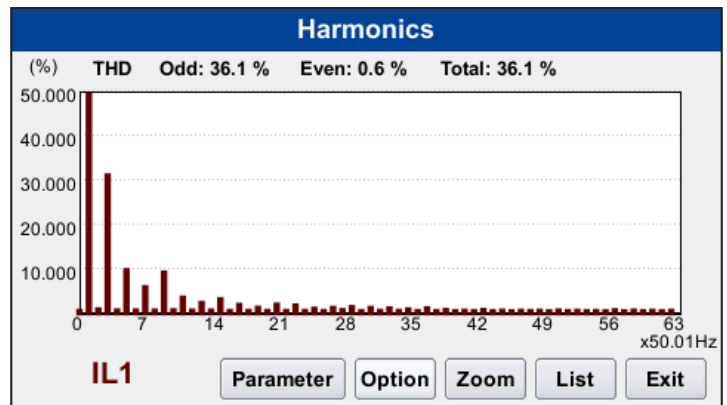

### Record:

- Recording of parameters as per EN50160 or as per user defined thresholds.
- Time Based recording offers automatic start & stop of recording without manual intervention.
- Comprehensive Setup Summary view to display thresholds & setting set for recording.
- Unique recording mode allows user to select recording mode as per user application.



### Events:

- Display & Analysis of recorded events like Dips, Swells & Interruptions.
- Waveform details at each specific Event.
- Display of Rms Values of Voltage & Current at recorded Events.

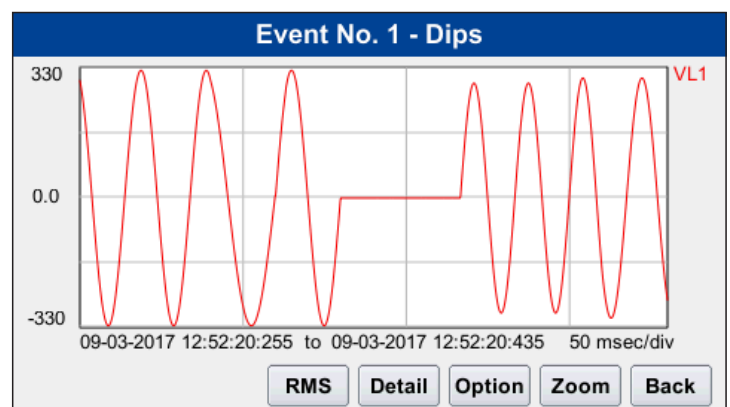

Measure



Control



Record



Analyze



### Trend:

- Graphical Trend Representation of parameters.
- Display of Values with Time Stamp.
- Zoom Function.

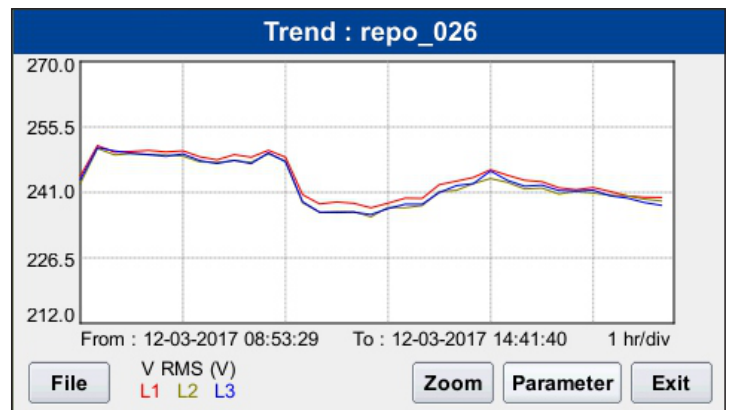

### Report:

- Automatic Report Generation as per EN50160 thresholds or user defined thresholds.
- Graphical View of EN50160 report for easy analysis.
- User Configurable Status Window.
- Color coded representation of configured parameter to locate the source and pin point root cause of Power Quality disturbance.

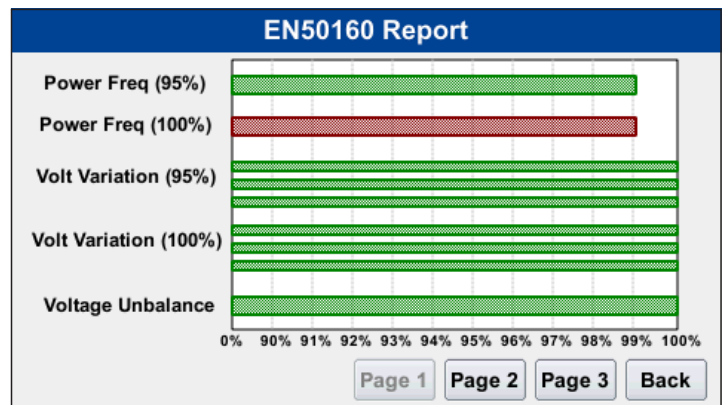

### Settings:

- System Config is used to select Wiring configuration, CT / PT values & Recording mode as per user need.
- Event threshold allows user to set thresholds for RMS faults.
- Trend Parameter, relay, communication setting.
- Setup Summary give details about **RiSH** PQA i.e. Model No, Wiring, CT/PT etc.

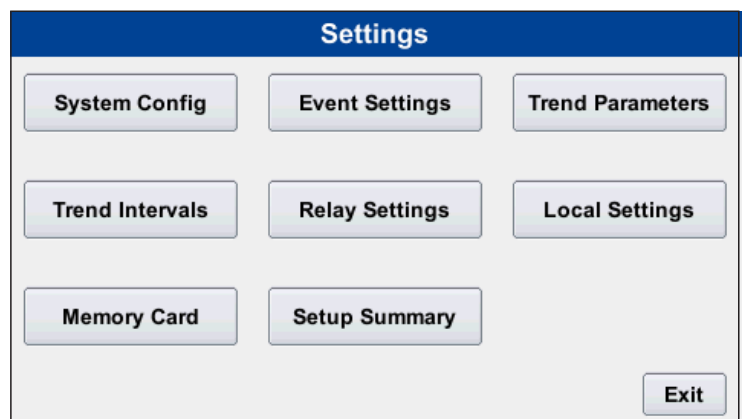

Measure



Control



Record



Analyze

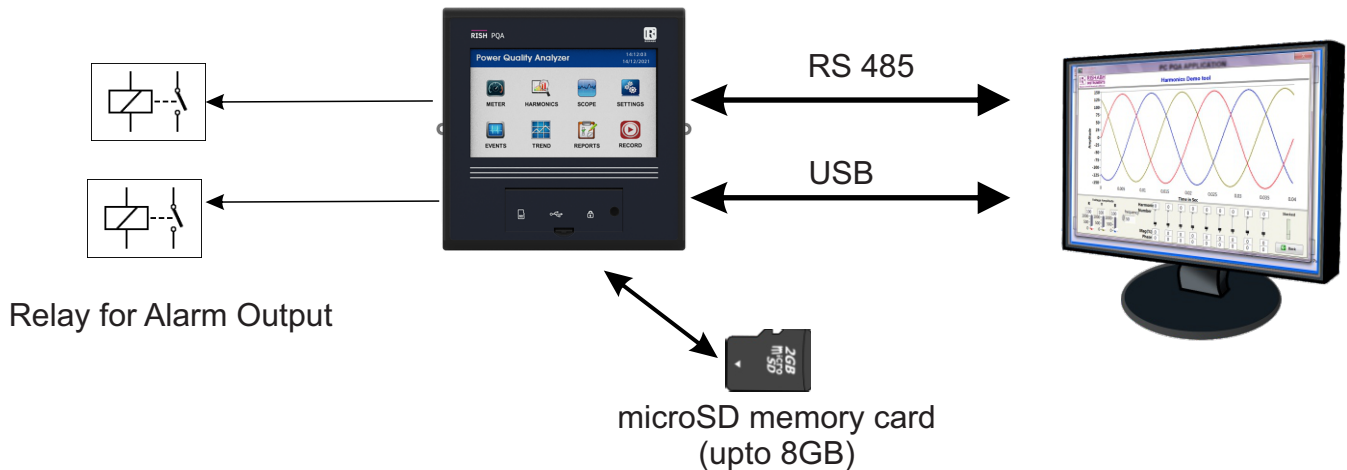

\*USB is only use to download the Data to the PC

### Technical Specifications:

Parameter	Measurement method	Uncertainty	Measuring range
Power Frequency	1 s and 10 s	$\pm 10$ mHZ	42.5 Hz ~ 57.5 Hz / 51 Hz ~ 69 Hz
Magnitude of the supply voltage	10 / 12 cycle	$\pm 0.1\%$ of $U_{din}$	10 % ~ 150 % of $U_{din}$
Input Current	10 / 12 cycle	$\pm 0.2\%$ of Nominal	0.1-200% of Nominal
Dips and swells	Urms (1/2)	Amplitude: $\pm 1\%$ of FS Duration: 1 + 1 cycle	duration > 2.5 cycles
Interruptions	Urms (1/2)	Duration: 1 + 1 cycle	duration > 2.5 cycles
Voltage / Current unbalance	10 / 12 cycle	$\pm 0.15\%$	0% - 5% of $U_1$
Voltage harmonics 1 to 63rd(Harmonics Grouping)	10 / 12 cycle	IEC 61000-4-7 class II  $\pm 5\% U_m$ $\pm 0.15\% U_{nom}$	10% ~ 200% of class 3 of IEC 61000-2-4 $U_m \geq 3\% U_{nom}$ $U_m < 3\% U_{nom}$
Current harmonics 1 to 63rd(Harmonics Grouping)	10 / 12 cycle	IEC 61000-4-7 class II  $\pm 5\% I_m$ $\pm 0.5\% I_{nom}$	10% ~ 200% of class 3 of IEC 61000-2-4 $I_m \geq 10\% I_{nom}$ $I_m < 10\% I_{nom}$
Voltage interharmonics 1 to 63rd(Interharmonics Grouping)	10 / 12 cycle	$\pm 10\% U_m$ $\pm 0.30\% U_{nom}$	10% ~ 200% of class 3 of IEC 61000-2-4 $U_m \geq 3\% U_{nom}$ $U_m < 3\% U_{nom}$
Current interharmonics 1 to 63rd(Interharmonics Grouping)	10 / 12 cycle	$\pm 10\% I_m$ $\pm 1.0\% I_{nom}$	10% ~ 200% of class 3 of IEC 61000-2-4 $I_m \geq 10\% I_{nom}$ $I_m < 10\% I_{nom}$

Note:  $U_{nom}$  /  $I_{nom}$  : Nominal Voltage / Current (TRMS),  $U_m$  /  $I_m$  : Measured Harmonic Voltage / Current  
 FS : Full Scale = 500 V.  
 10 cycle for 50 Hz and 12 cycle for 60 Hz. Reference channel for frequency detection is Phase L1.  
 $U_1$  : Positive sequence voltage



Measure



Control



Record



Analyze





### Technical Specifications:

<b>Real Time Clock (RTC) uncertainty:</b>	±1 Sec/Day (23°C ± 1°C) (Trimmable through display or Modbus)
<b>Display update rate:</b>	
Response time to step input	1 sec approx.
<b>Interfaces:</b>	
Impulse Led	At front of the instrument.
Relay Output	Configured as limit.
Load Capacity	240 V AC ,5 A
Contact	Change over contact, bistable
ModBus / RTU	RS485, max. 1200m Baud rate: 9.6k, 19.2k, 38.4k, 57k, 115.2k bps
<b>USB</b>	At front side of instrument
<b>SD card interface</b>	MicroSD Up to 8 GB (Maximum event recorded per file is 4000)
<b>Overload Indication</b>	"OL"
Voltage	>760 V L-N
Current	>205 % of CT Secondary

### Electrical Connection:

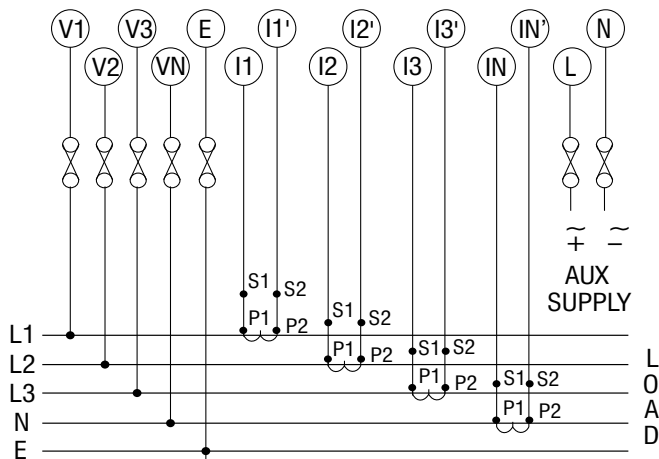

a) 3 Phase 4 Wire

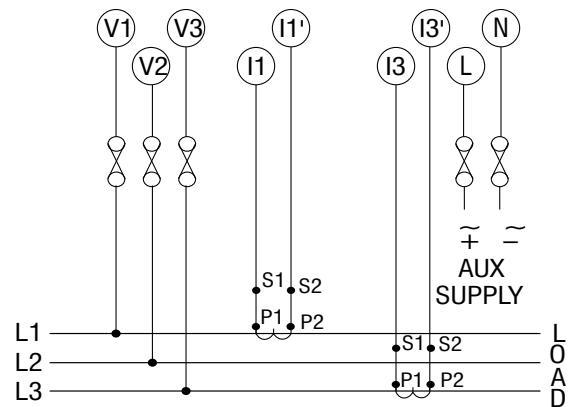

b) 3 Phase 3 Wire

### Dimension Details:

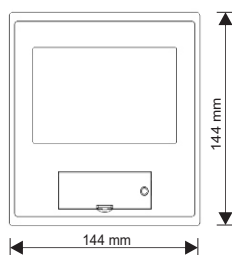

Front View

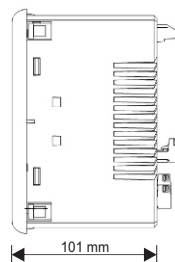

Side View

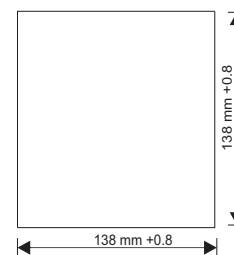

Panel Cutout

### Ordering Information:

**Ordering Information**  
Rish PQA with USB, Modbus

**Ordering Code**  
RISH PQA - U - M



Measure



Control



Record



Analyze



RISHABH

All specifications are subject to change without notice



Measure



Control



Record



Analyze

## RISHABH INSTRUMENTS LIMITED

Domestic (India): +91 253 2202028/99 | [marketing@rishabh.co.in](mailto:marketing@rishabh.co.in)

International: +91 253 2202004/06/08/99 | [global@rishabh.co.in](mailto:global@rishabh.co.in)

[www.rishabh.co.in](http://www.rishabh.co.in)