

361, 362, 363 and 364 Challenger Series Panel Meters

Data Sheet

361, 362, 363 and 364
Challenger Series
Panel Meters

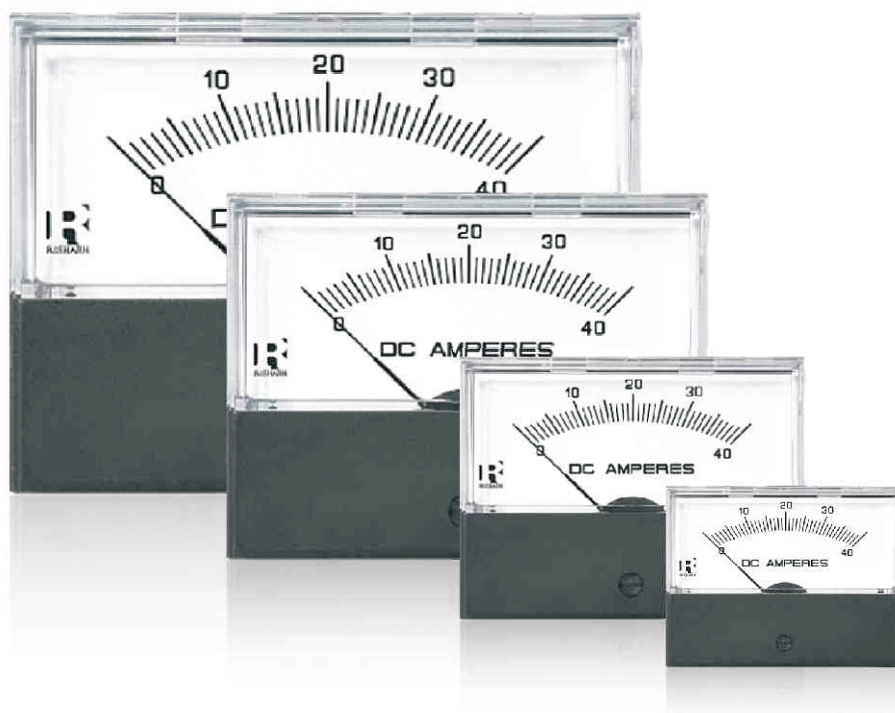

Application

The Challenger range of analog panel meters offers accurate measurement and indication of most electrical and electronic parameters in industry standard 1^{1/2} ", 2^{1/2} ", 3^{1/2} ", and 4^{1/2} " case sizes. This innovative design features a detachable lower fascia plate which allows the flexibility of either surface or window mounting. The fascia is simply unclipped to achieve the completely flush panel appearance of panel window mounting.

The range offers AC and DC ammeters, voltmeters and frequency meters utilizing a high torque pivot and jewel movement. AC moving coil rectified meters provide 1.5% accuracy of the full scale value and features a rear zero adjuster screw for tamper proof installation. AC moving iron meters also provided 1.5% high accuracy and true RMS measurement.

Applications :

- Marine
- Switchgear
- Distribution systems
- Control panels
- Embedded generation
- Energy management
- Building management
- Utility power monitoring
- Process control
- Motor monitoring

Features

- Measuring and indication of AC amps, volts, frequency and DC signals.
- Surface or window mounting.
- Rear zero adjuster on moving coil meters.
- High torque pivot and jewel movement.
- True RMS measurement meters.
- * AC and DC inputs.
- Up to 40A DC direct connected.
- Up to 50A AC direct connected.

(Not applicable for model 361)*

Benefits

- AC moving iron and moving coil mechanisms.
- ANSI standard case sizes.
- Detachable lower fascia plate.
- Easy to modify for distributions.

Compliant With

- ANSI C39.1

Applicable Standards

Nominal case and cutout dimensions for indicating electrical instruments.	: IS 2419
Scale and pointer for electrical measuring instruments.	: IS 1248, IEC 51 DIN 43802
Connections and Terminal markings for panel meters	: IS 1248, IEC 51 DIN 43807
Terminal bolts	: DIN 46200/46282
Safety requirements and protective measures for Electrical indicating instruments and their accessories.	IS 9249 DIN 40050 / 8-70 VDE 0110 /11-72 VDE 0410 /10-76 IEC 529, IEC 1010
Performance specifications for direct acting indicating analogue electrical measuring instruments & their accessories	: IS 1248 IEC 51
Environmental conditions	: IS 1248, IEC 51 IS: 9000, Part 5, 7, 8, VDE / VDI 3540
UL Combustibility class.	: UL 94 V-O
Technical conditions of delivery for electrical instruments.	: DIN 43701
Mechanical strength (Free fall test, vibration test)	: IS 1248/IEC 51 IS 9000 VDE 0411, part I, Sec.43/44, IEC 1010

Comply with following European directives : 2004 / 108 / EC (EMC directive), 2006/95/EC (low voltage directive) & amendment 93/68/EEC, for CE Marking.

Specifications

Accuracy	
DC Ammeters and Voltmeters	1.5% 0 to 100% of full scale deflection
AC Ammeters and Voltmeters	Moving Iron: 1.5% 10 to 100% of full scale deflection
Frequency Meters	0.5% of end scale value
Input Ratings	
DC Moving Coil Ammeters	50mA to 50A
DC Moving Coil Voltmeters	50 mV to 600V
AC Moving Coil Ammeters (VQ)	1mA to 1A
AC Moving Coil Voltmeters (VQ)	6V to 600V
AC Moving Iron Ammeters (EQ)	100mA to 60A
AC Moving Iron Voltmeters (EQ)	6V to 600V
Frequency meters	45-50-55Hz, 55-60-65Hz, 45-55-65Hz
Burden	20 to 500V AC. Standard 900ohms/volt
Overload	
Voltmeters	2 times for 0.5 sec : 9 overloads 2 times for 5 sec : 1 overload
Ammeters	10 times for 0.5 sec : 9 overloads
DC Center Zero Voltmeter	10 times for 5 sec : 1 overload
Enclosure	
Movement	High torque pivot and jewel moving coil and moving iron
Scale Balance	Within 1% of scale length
Relative Humidity	25% to 80% nominal range of use
Operating Temperature	0° C to +40° C
Storage Temperature	20° C to +55° C
Enclosure Code	IP42
Case and Cover	Matt black case UL94V. Polycarbonate cover
Bezel	Matt black
Bezel Window	Shatterproof polycarbonate
Fixing	Surface mounting: 4 corner studs, 4-40 UNF Rear of panel mounting: 2 through hole mounts
Compliant With	
Performance	ANSI C39.1 and IEC 51
Manufacture	UL3111-1
Scaling	ANSI C39.1
Safety	IEC61010-1 (LVD) and BS EN 61326: (EMC)
Vibration	ANSI C39.1 cl. 5.13

Operation

Moving Coil Meter

These meters offers a centre cored, self shielding moving coil movement using pivots, hairsprings and sprung jewels. Variations in movement are limited by design. All DC voltmeters are 1000 ohms per volt, moving coil rectified products run at 900 ohms per volt. Milivolt meter use the 5 miliamps/50mV resistance.

Moving Iron Meter

This clapper type repulsion design utilizes a pivot, hairspring and jewel movement. The bottom jewel is oil filled to provide damping while the top is spring for resilience. All voltmeters are manufactured with internal voltage dropper resistors.

Frequency Meter

Frequency meters use a 1mA/350ohm movement driven by an EMC hard frequency conversion circuit.

Dials, Pointers and Scales

Standard dials are matt white black printed scales and a tubular knife-edge black are balanced within 1% of scale length and feature a highly repeatable flattened are scale shape, ensuring consistently accurate measurement reading. Dials are interchangeable between the challenger range of products using the same input within the published specification of the meter. Options for non standard customer specific dials are available upon request.

Dimensions

Surface Mount Cut Out

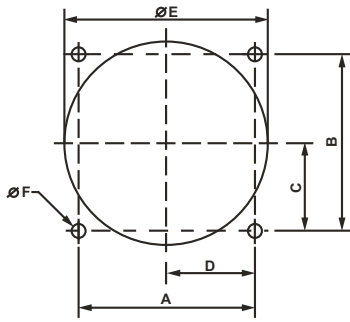

Model 362 and 363 Surface Mount Cut Out

	A	B	C	D	E	F
362 INCHES	1.88	1.88	0.94	0.94	2.16	0.15
362 MM	47.8	47.8	23.9	23.9	54.9	3.8
363 INCHES	2.25	2.25	1.12	1.12	2.16	0.16
363 MM	57.2	57.2	23.4	28.5	54.9	3.6

Window Mounting Cut Out

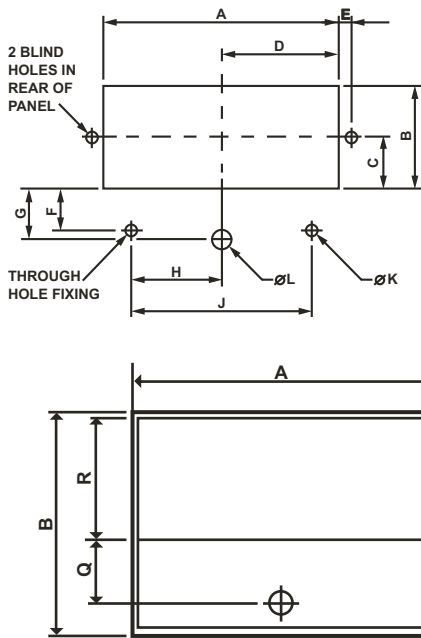

Model 362 and 363 Window Mounting Cut Out

	A	B	C	D	E	F	G	H	J	K	L
362 INCHES	2.92	1.28	0.63	1.46	0.16	0.64	0.81	1.13	2.26	0.14	0.23
362 MM	74.2	35.5	16.0	37.1	4.1	16.3	20.6	28.7	57.4	3.6	5.8
363 INCHES	3.63	1.61	0.8	1.82	0.16	0.81	0.81	1.48	2.96	1.14	0.23
363 MM	92.2	40.9	20.3	46.2	4.1	20.6	20.6	37.6	75.2	3.6	5.8

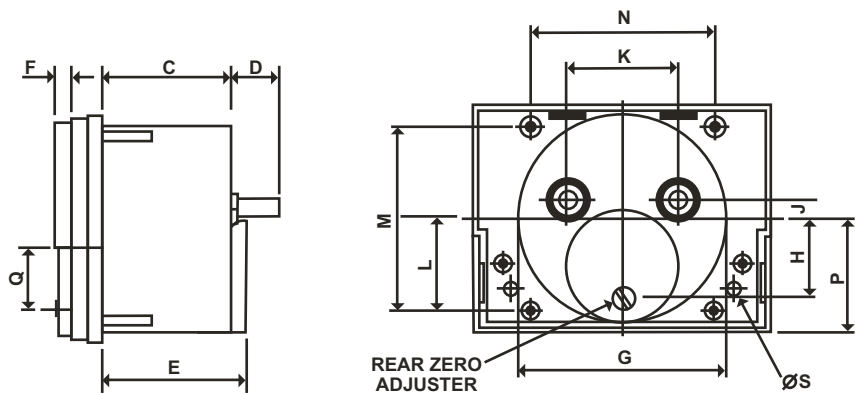

Model 362 and 363

	A	B	C	D	E	F	G	H	J	K	L	M	N	P	Q	R	S
362 INCHES	3	2.3	1.3	0.5	1.46	0.15	2.12	0.81	0.2	1.12	0.94	1.88	1.88	1.16	0.63	1.27	0.14
362 MM	76.2	58.5	33.0	12.7	37.0	3.8	53.8	20.6	5.1	28.4	23.9	47.8	47.8	29.5	16.0	32.4	3.6
363 INCHES	3.75	2.91	1.3	0.5	1.46	0.16	2.12	0.81	0.2	1.12	0.92	2.25	2.25	1.25	0.81	1.42	0.14
363 MM	95.3	73.9	33.0	12.7	37.0	4.1	53.8	20.6	5.1	28.4	23.4	57.2	57.2	31.8	20.6	36.1	3.6



RISHABH
Measure, Control & Record with a Difference

**RISHABH
INSTRUMENTS**

RISHABH INSTRUMENTS PVT.LTD.

F-31, MIDC, Satpur, Nashik-422 007, India.

Tel.: +91 253 2202160, 2202202 Fax : +91 253 2351064

E-mail : India :- marketing@rishabh.co.in

International :- exp.marketing@rishabh.co.in

www.rishabh.co.in